

A. Common General Cleaning Plant

Aquablast Machine.

1



Model.	Turntable Ø (mm)	Work Height(mm)	Table Load Capacity(kg)	Heavy Duty Capacity(Kg)
AB750	750	1000/1290	450	670
AB1010	1010	980/1550	680	1580
AB1310	1310	1200/1850	1100/1800	1350
AB1500	1500	1800/2800	3390	6750
AB1800	1800	1850	4500	9050
AB2100	2100	1850	4500	9050
AB2550	2550	1850	4500	9050

Aquablast cleaning plant cleans any kind of grease and dirt with the help of blast of hot chemical . The choice of chemical and selection of temperature and pressure of hot chemical is important.

Our wide range of machine cater to many industries viz bearing refurbishment, engine cleaning and cleaning of any parts. Caters to small and large garages, CTRB refurbishment plants, large object , intricate shapes , cleaning of steel, aluminum , SS parts etc.

Parts Cleaning Machine.

2



Model.	Parts quantity	Work Height(mm)	Machine Length & Width(mm)
PC10	10	900	2000 x 1000
PC15	15	900	2500 x 1500
PC20	20	900	3000 x 2000

This machine has a rotary hanger in which components can be mounted and parts can be cleaned through spray of hot chemical or kerosene oil. This machine is not as effective as Aquablast machine but cleans simple parts effectively.

B.CTRB Refurbishment Specific Cleaning Plant

Grease Purging Machine.

1		Model.	Cone assembly Quantity	Work Height(mm)	Machine Length & Width(mm)
		GP2	2	1200	1550 x 500
		GP4	4	1200	1550 x 1020
		GP6	6	1200	1550 x 1550
		<p>The Cone assemblies are mounted and rotated at high speed. The grease inside comes out with the help of centripetal force. This process reduces the burden on subsequent cleaning of Cone Assemblies.</p> <p>According to the requirement of customers this machine can be made to accept 2 , 4 or 6 cone assemblies at a time.</p> <p>However bearings with polymer cages cannot be cleaned in Grease Purging Machine.</p>			

Grease loosening Machine.

2		Model	Cone assembly quantity	Work Height(mm)	Machine Length & Width(mm)
		GL2	2	1150	1000 x 800
		GL4	4	1150	2000 x 800
		GL6	6	1150	3000 x 800
		<p>Followed by Grease Purging Grease loosening is done in CTRB Refurbishment plants.</p>			

Automatic Cone Cleaning Machine

3		Model.	Cone assembly quantity	Work Height(mm)	Machine Length & Width(mm)
		CC2	2	1100	2100 x 800
		CC4	4	1100	3100 x 800
		CC6	6	1100	4100 x 800

C. CTRB Dis-assembly & Assembly Fixtures

Hydraulic Press.

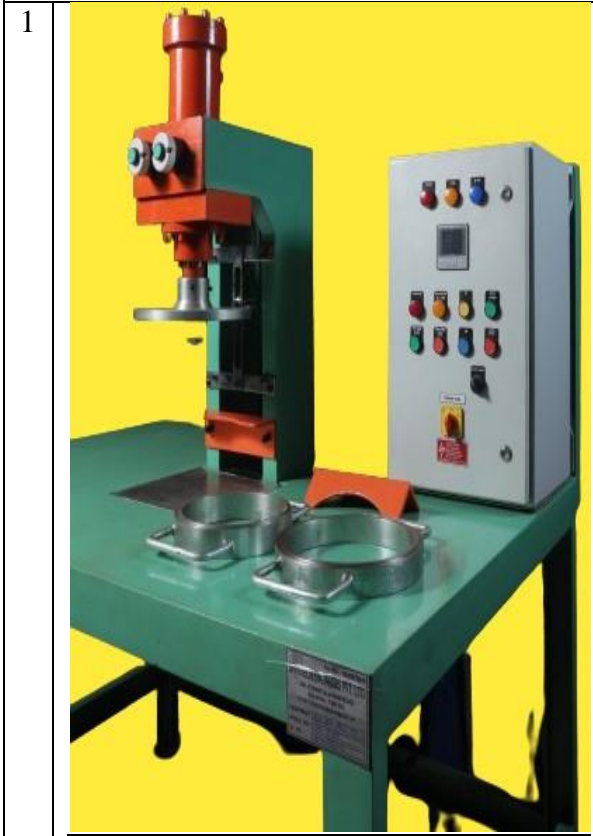

Model.	Work Height(mm)	Machine Length & Width(mm)
HPDIS800	800	1500 x 1000

Manual Operated Press.



Model.	Work Height(mm)	Machine Length & Width(mm)
MP800	800	2000 x 1000

D. CTRB Specific Inspection Fixture

Bearing Cage Inspection Fixture

1		Model.	Bearing Class (Inch)	
		BC-B	4-1/4 x 8	
		BC-C	5 x 9	
		BC-D	5-1/2 x 10	
		BC-E	6 x 11	
		BC-F	6-1/2 x 12	
		BC-G	7 x 12	

Cone assembly Bore Checking Fixture

2		Model.	Bearing Class (Inch)	
		CB-B	4-1/4 x 8	
		CB-C	5 x 9	
		CB-D	5-1/2 x 10	
		CB-E	6 x 11	
		CB-F	6-1/2 x 12	
		CB-G	7 x 12	

Double Cup Outside Diameter Checking Gauge

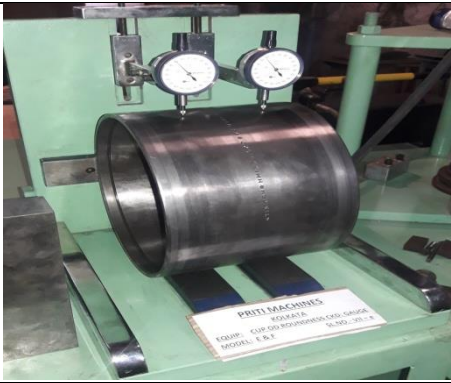
3		Model.	Bearing Class (Inch)	
		DC-B	4-1/4 x 8	
		DC-C	5 x 9	
		DC-D	5-1/2 x 10	
		DC-E	6 x 11	
		DC-F	6-1/2 x 12	
		DC-G	7 x 12	

Comparator for Spacer Width

4		Model.	Bearing Class (Inch)	
		SW-B	4-1/4 x 8	
		SW-C	5 x 9	
		SW-D	5-1/2 x 10	
		SW-E	6 x 11	
		SW-F	6-1/2 x 12	
		SW-G	7 x 12	

Bearing Seal Lip Groove Inspection Fixture

5



Model.	Bearing Class (Inch)
B	4-1/4 x 8
C	5 x 9
D	5-1/2 x 10
E	6 x 11
F	6-1/2 x 12
G	7 x 12

E. HYDRAULIC BEARING PULLER & PUSHER..

1



Model.	Bearing Class (Inch)
B	4-1/4 x 8
C	5 x 9
D	5-1/2 x 10
E	6 x 11
F	6-1/2 x 12
G	7 x 12

F. Manipulator

1

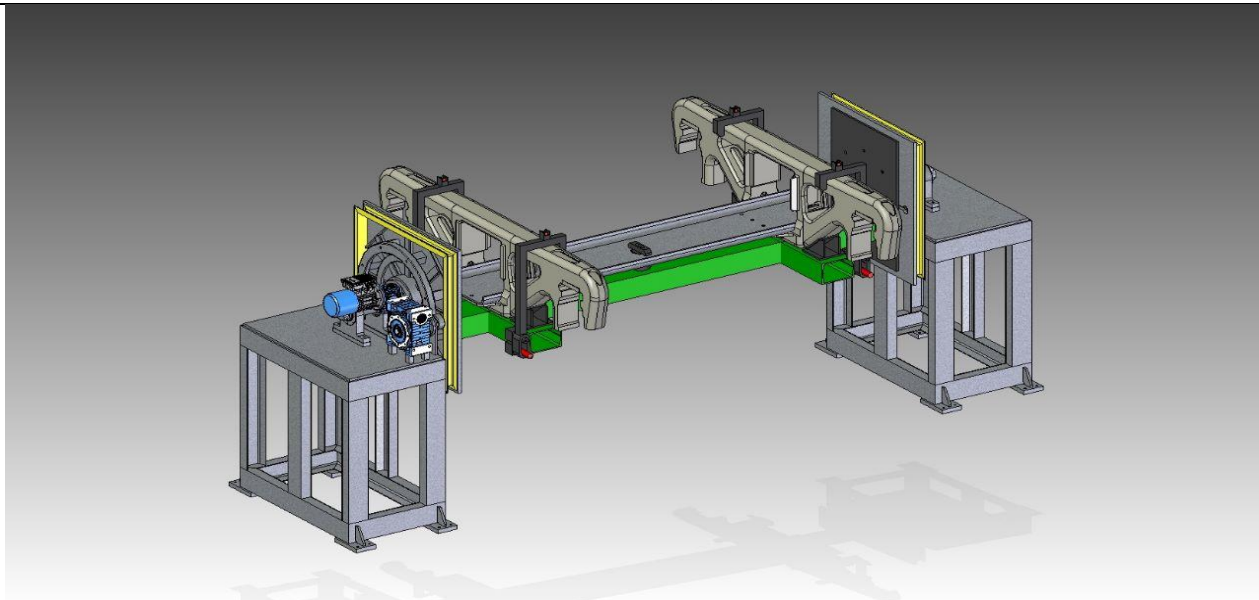

Bolster Manipulator

2



Casnub Bogie Holding Fixture Assembly.

MISCELLANEOUS FIXTURES FOR RAILWAYS

1



Screw Type Jack For Coach Lifting

2. Transformer Trolley.



Lifting The Transformer of Locomotive.

3. Dipolory.



Model.- LHB Shell, MEMU/DMC Coach, High & Low Train - 18

3. Bogie Turn Table.

